



# TORINCAB2 s.r.l.

SEDE LEGALE ED AMMINISTRATIVA:  
Via DRUBIAGLIO 6/17  
10040 Frazione RIVERA – ALMESE (TO)  
TEL. (0039) 0119352688  
FAX. (0039) 0119352838

Cap. Soc. € 10.000,00  
Isc. al Reg. delle Imp. di Torino n. 05655530011  
Albo Imprese Artigiane n. 307836  
Partita IVA e Cod. Fisc. 05655530011  
E-mail: [info@torincab2.com](mailto:info@torincab2.com)  
Sito: [www.torincab2.com](http://www.torincab2.com)

## UNIVERSAL CABIN



**THE CABIN CAN BE MOUNTED ON EVERY TRACTOR OF  
MEDIUN AND SMALL SIZE ALSO UNDER THE ROLL-BAR**

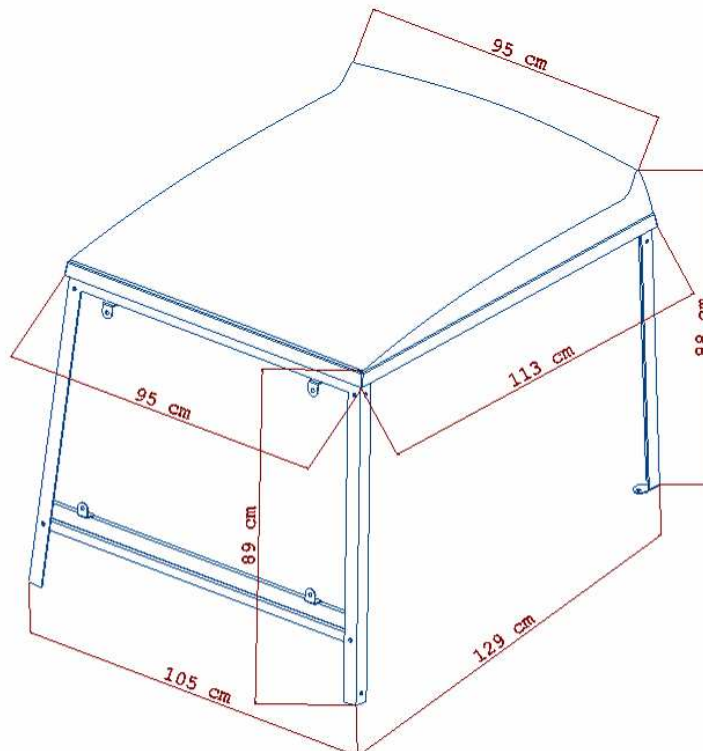

# TECHNICAL FEATURES:

## COMFORT MODEL

- ABS ROOF
- STRENGTHENED WINDSCREEN FIXED ON FRONT FRAME
- FRONT ELECTRIC WINDSCREEN WIPER
- BACK FRAME FOR MOUNTING ON TRACTOR
- TRASPARENT SLIDING CLOTH AS DOORS AND BACK CLOSING
- FIXING FITTING
- FRONT CLOSING CLOTH AROUND ON DASHBOARD

## SPECIAL MODEL

### COMFORT MODEL EQUIPEMENT +

- FRONT ELECTRIC WINDSCREEN WIPER WITH DOUBLE POWER
- LEFT HOMOLOGATED DRIVING MIRROR
- FRONT LIGHTS (THE PAIR)
- SUNSHADE

## ON REQUEST

- LEFT HOMOLOGATED DRIVING MIRROR
- FRONT LIGHTS (THE PAIR)
- SUNSHADE
- FLASHING LIGHT SOCKET
- FLASHING LIGHT

