



TORINCAB2 s.r.l.

SEDE LEGALE ED AMMINISTRATIVA:
Via DRUBIAGLIO 6/17
10040 Frazione RIVERA – ALMESE (TO)
TEL. (0039) 0119352688
FAX. (0039) 0119352838

Cap. Soc. € 10.000,00
Isc. al Reg. delle Imp. di Torino n. 05655530011
Albo Imprese Artigiane n. 307836
Partita IVA e Cod. Fisc. 05655530011
E-mail: info@torincab2.com
Sito: www.torincab2.com

UNIVERSAL CABIN



**THE CABIN CAN BE MOUNTED ON EVERY TRACTOR OF
MEDIUN AND SMALL SIZE ALSO UNDER THE ROLL-BAR**

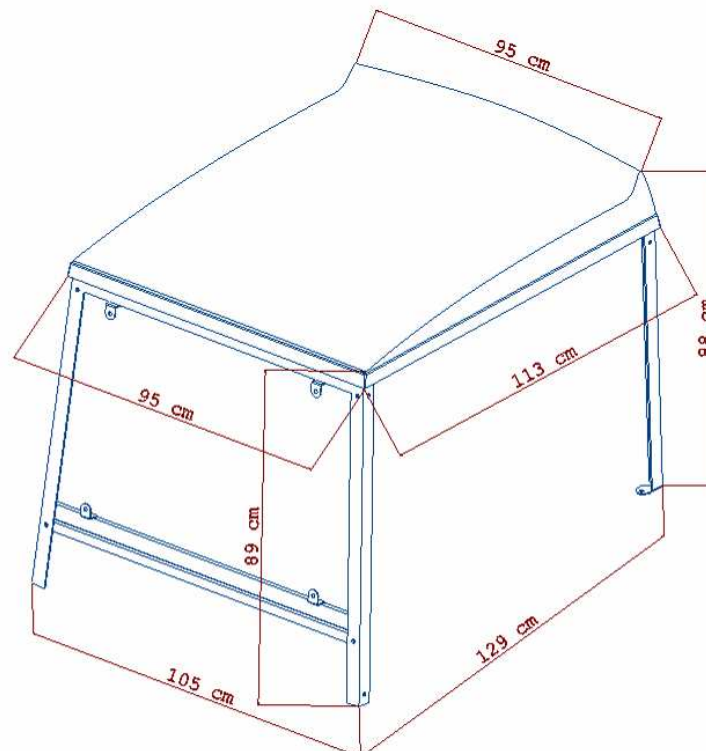

TECHNICAL FEATURES:

COMFORT MODEL

- ABS ROOF
- STRENGTHENED WINDSCREEN FIXED ON FRONT FRAME
- FRONT ELECTRIC WINDSCREEN WIPER
- BACK FRAME FOR MOUNTING ON TRACTOR
- TRASPARENT SLIDING CLOTH AS DOORS AND BACK CLOSING
- FIXING FITTING
- FRONT CLOSING CLOTH AROUND ON DASHBOARD

SPECIAL MODEL

COMFORT MODEL EQUIPEMENT +

- FRONT ELECTRIC WINDSCREEN WIPER WITH DOUBLE POWER
- LEFT HOMOLOGATED DRIVING MIRROR
- FRONT LIGHTS (THE PAIR)
- SUNSHADE

ON REQUEST

- LEFT HOMOLOGATED DRIVING MIRROR
- FRONT LIGHTS (THE PAIR)
- SUNSHADE
- FLASHING LIGHT SOCKET
- FLASHING LIGHT

