



TORINCAB2 s.r.l.

SEDE LEGALE ED AMMINISTRATIVA:
Via DRUBIAGLIO 6/17
10040 Frazione RIVERA – ALMESE (TO)
TEL. (0039) 0119352688
FAX. (0039) 0119352838

Cap. Soc. € 10.000,00
Isc. al Reg. delle Imp. di Torino N. 05655530011
Albo Imprese Artigiane N.307836
Partita IVA e Cod. Fisc. 05655530011
E-mail: info@torincab2.com
Sito: www.torincab2.com

NUOVA CABINA TORINCAB PER SERIE:

FERRARI

VEGA V80 - 75 - 85 - 95

AR Reversibile

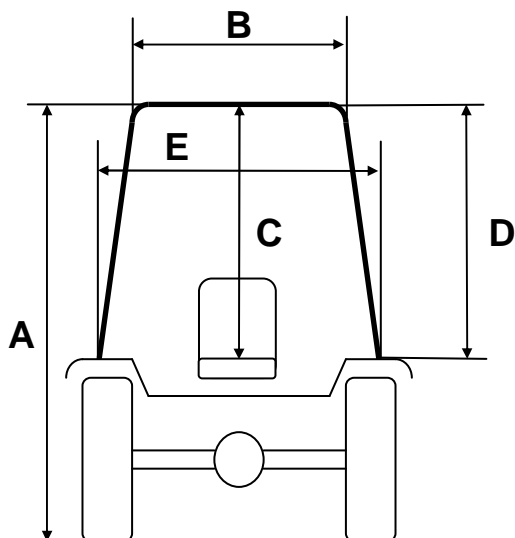

Cabina FERRARI VEGA AR Rev.
Gommatura Trattore 320/65 R.18

A	2130	mm
B	800	mm
C	990	mm
D	1130	mm
E	990	mm